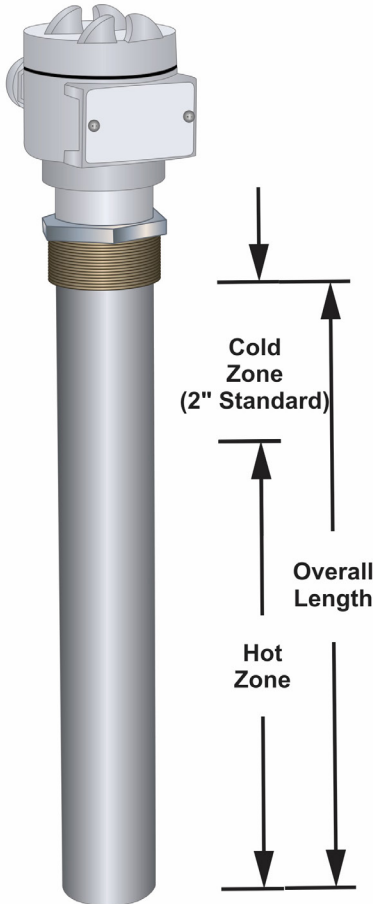

SCREWPLUG METAL HEATER

**INFORMATION**

- Durable, efficient chemical heater
- Screwplug heater in 304 stainless steel, 316 stainless steel, or titanium elements suitable for use in most aqueous alkaline solutions and plating and phosphate tanks
- Grounded construction
- Heats up to 180°F (82°C)
- Power range: 1000-12000 watts
- Operates on 120-480 volts

FEAUTRES

- 304 stainless steel, 316 stainless steel, or titanium elements suitable for use in most aqueous alkaline solutions and plating and phosphate tanks
- Watt densities up to 35 watts/square inch (5.4 w/cm²)
- Vapor resistant, flame retardant PVC terminal enclosure with 3 ft. (.9m) flexible Teflon liquid tight conduit
- Grounded construction



STANDARD PARTS

304SS	316SS	TITANIUM	WATTS	VOLTS	OVERALL LENGTH	THREAD SIZE
IM-FT1110	IM-ST1110	IM-TT1110	1000 W	120 V	10 "254 mm	2" NPT
IM-FT1210	IM-ST1210	IM-TT1210	1000 W	240 V	10 "254 mm	2" NPT
IM-FT2114	IM-ST2114	IM-TT2114	2000 W	120 V	14 "356 mm	2" NPT
IM-FT2214	IM-ST2214	IM-TT2214	2000 W	240 V	14 "356 mm	2" NPT
IM-FT2414	IM-ST2414	IM-TT2414	2000 W	480 V	14 "356 mm	2" NPT
IM-FT3219	IM-ST3219	IM-TT3219	3000 W	240 V	19 "483 mm	2" NPT
IM-FT3419	IM-ST3419	IM-TT3419	3000 W	480 V	19 "483 mm	2" NPT
IM-FT4223	IM-ST4223	IM-TT4223	4000 W	240 V	23 "584 mm	2" NPT
IM-FT4423	IM-ST4423	IM-TT4423	4000 W	480 V	23 "584 mm	2" NPT
IM-FT6233	IM-ST6233	IM-TT6233	6000 W	240 V	33 "838 mm	2" NPT
IM-FT6433	IM-ST6433	IM-TT6433	6000 W	480 V	33 "838 mm	2" NPT
IM-FT8240	IM-ST8240	IM-TT8240	8000 W	240 V	40 "1016 mm	2" NPT
IM-FT8440	IM-ST8440	IM-TT8440	8000 W	480 V	40 "1016 mm	2" NPT
IM-FT9247	IM-ST9247	IM-TT9247	9000 W	240 V	47 "1194 mm	2" NPT
IM-FT9447	IM-ST9447	IM-TT9447	9000 W	480 V	47 "1194 mm	2" NPT
IM-FT12261	IM-ST12261	IM-TT12261	12,000 W	240 V	61 "1549 mm	2" NPT
IM-FT12461	IM-ST12461	IM-TT12461	12,000 W	480 V	61 "1549 mm	2" NPT

*Single phase standard, 3-phase available.

3-4 Week Lead Time for Standard & Custom Products!

ORDER CODE

IM-XX	XX	X	XX		
SERIES	WATTAGE	VOLTAGE	OVERALL LENGTH (in)	OPTIONS	WIRE & CONDUIT LENGTH
FT 304 stainless steel	1 1000	1 120V	10 1kW	No Designator = Single Phase Power (std)	blank - 36" TEFLON CONDUIT
ST 316 stainless steel	2 2000	2 240V	14 2kW		
TT Titanium	3 3000	3 380V	19 3kW	-3 = three Phase Power	SPECIFY LENGTH - EX. X84 = 84" TEFLON CONDUIT
	4 4000	4 480V	23 4kW		
	6 6000	5 415V	33 6kW		
	8 8000	6 600V	40 8kW		
	9 9000	7 400V	47 9kW		
	12 12000	8 208V	61 12kW		
		9 220V	Specify (custom lengths available)		
		0 200V			

EX. IM-ST4523-X72 SCREWPLUG MET-AL 316SS Immersion Heater, 4kW, 415V, 23" Overall Length, 72" Teflon Conduit